



by Kelly Davidson

Randy Richmond's full-electric-powered GMC Sonoma pickup, converted using a commercial kit.

For nearly a decade, engineer Randy Richmond explored the idea of owning an electric vehicle (EV). He scouted out the latest technology at renewable energy fairs and read countless blogs, articles, and Web sites devoted to the topic. His interest even grew into a side business with his family—RightHand Engineering, a designer and seller of software tools that monitor RE and EV systems.

Although he'd hoped to buy a new factory-made electric vehicle, that dream died when most leading manufacturers

stopped production in the late 1990s. When gasoline prices reached more than \$3 per gallon, he wondered if gas rationing would soon follow—a repetition of the 1973 oil crisis. Imagining people lined up by the hundreds to fill their fuel tanks was the final push he needed.

"I realized that the time had come, and I had to do it on my own. There was no use waiting for the auto industry because I'd wait forever," he says. "I no longer wanted to contribute to the problems in the Middle East, and I wanted a vehicle more consistent with my renewable energy lifestyle and business."

Out with the internal combustion engine.



Lots of room in the engine compartment.



In April 2006, Richmond started running the numbers and asking lots of questions. Before committing to an EV conversion, he considered the “easier” alternatives, such as buying a specialized EV, like the Myers Motors Sparrow/Nmg or the ZAP Xebra, or buying a used, factory-produced model like the Toyota RAV4 EV, Chrysler EPIC minivan, GM S-10 EV pickup, or Ford Ranger EV pickup. Either too small, too slow, too expensive, or too hard to find, none of them were a good match for his needs.

Devising a Plan

Richmond found an invaluable resource in the Electric Auto Association, a nonprofit organization that promotes the advancement and widespread adoption of EVs. Through the Web site, he connected with other electric car enthusiasts, who were happy to answer his countless questions. With the guidance of their triumphs and failures, he developed his plan of action, and by May, he was ready.

Even with an electrical engineering degree from the University of Washington and a longtime interest in electric vehicles, Richmond considered hiring a private EV enthusiast or commercial EV conversion company to do the conversion.

“If you cannot do standard mechanical repairs to your vehicle, basic electrical wiring around your home, or remove an engine, you should not do the conversion yourself,” he says. “Don’t hesitate to pay someone to do it, or buy a vehicle that’s already converted. Working on conversions isn’t for everyone.”

Ultimately, after evaluating his electrical and mechanical skills, Richmond felt comfortable moving forward with a “do-it-yourself” EV conversion. He did, however, recognize his limitations with metal fabrication and welding, and formulated his plan accordingly.

From the get-go, he knew a piecemeal approach—buying the parts individually—might be too complicated. Customizing adapters and mounts went beyond his skill level. He decided that a conversion kit—which comes equipped with most of the mechanical parts—would best suit his needs and abilities.



Randy Richmond takes his electric truck to auto events to help spread the word on EV practicality and performance.

Choosing a Vehicle

Richmond says that establishing realistic needs is one of the first and most important steps in the process of vehicle selection. How far do you need to go each day? How fast do you need to go? What kind of acceleration do you need? How much do you want to be able to haul? What kind of weather will you need to travel in? The answers to these and other questions will determine the vehicle, vendor, and components used for the conversion, as well as the design and EV conversion approaches.

The 100 hp DC motor bolted to the original transmission.



Installing the new electric motor and transmission, with room to spare.





Above the drive motor— six T-145 lead-acid batteries and the control box, mounted to the left of the batteries.

Richmond carefully evaluated his weekly commute: four 18-mile trips along local, rural roads near his home in Woodinville, Washington, and one 40-mile trip to nearby Issaquah with some distance on Interstate 405. The highway driving, though brief, necessitates that the vehicle reach 60 mph. He needed enough horsepower to handle the extra weight of the batteries in the vehicle and get up the hills along his commute. He decided against power-intensive air conditioning and power steering but elected for power brakes and electric heating, given the weight of the vehicle and the cool, rainy conditions in the area. Though the vehicle would be used primarily for commuting, he wanted enough seating for his family.

He knew that a small car or a neighborhood electric vehicle (NEV) would not suit his needs. He quickly turned his attention to pickup trucks. With a convenient place for batteries and the capacity to handle extra weight, small pickup trucks tend to be the easiest to convert. Plus, there is a greater chance of finding a cost-effective and easy-to-use conversion kit, says Richmond, since there are several kits made for pickup trucks.

In the bed—a custom battery box holds eighteen T-145s.



A mechanically sound vehicle is key to a successful conversion. "The vehicle had to be something that I would be happy to drive," he says. "I did not want to invest my time and money into an unsound or unsightly vehicle. I wanted a vehicle that was in good shape and had some longevity." A late-model 2001 GMC Sonoma pickup with an extended cab, five-speed transmission, and fewer than 80,000 miles on its odometer filled the bill.

Getting the Goods

"The EV conversion kit industry is not quite mainstream," Richmond says. "You have to shop around, pick and choose, and be patient."

After some Web research, he decided to purchase the S-10/Sonoma kit from Canadian Electric Vehicles Ltd. Randy Holmquist and his team in British Columbia have more than 12 years of experience with electric vehicles, but it was the responsive customer service and attention to detail that won Richmond over. Unlike some other distributors that just provide raw materials and instructions for fabrication, CanEV prefabricates all the adaptors, mounts, brackets, and boxes—virtually eliminating fabrication from the installation process.

The \$10,700 cost of the kit did not include batteries, the controller cooling system, or the battery state-of-charge meter. The controller cooling system—a water circulating pump and miniature radiator—came from EV Source, a distributor based in Logan, Utah.

To save on shipping, Richmond purchased the 1,800 pounds of batteries from Allied Batteries in Seattle. The kit recommended 225 amp-hour (AH) golf cart batteries, but Richmond chose ones with a slightly higher capacity—24 Trojan T-145 (6 V, 260 AH)—to achieve a greater driving range. Richmond's company—RightHand Engineering—supplied the Xantrex Link-10 battery state of charge (SOC) meter.

The kit arrived on time with all the parts needed for the conversion—except for the controller and charger, which Richmond decided to customize to his application. By upgrading from a 120-volt charger to a 240-volt charger, he reduced the battery charge time from 12 hours to 4 hours. He swapped out the 300 A Curtis controller included in the CanEV kit for a Café Electric Zilla controller, which offers PC interface capabilities. The Zivan battery charger and Zilla controller took four months to arrive because both manufacturers had a backlog of orders.

Wiring Critical Connections

While waiting for the back-ordered parts to arrive, Richmond wired the control box. As the central hub for the vehicle's wiring, the control box contains all the relays that connect the main battery bank to the vehicle systems. Wiring the box took more than 30 hours.

Although CanEV can pre-wire the main control box, a bonus for those who are less familiar with electrical wiring, Richmond saved money—roughly \$1,000—by doing it himself and maintained the flexibility to tweak the kit's electrical design.

Custom GMC Sonoma Electric Vehicle

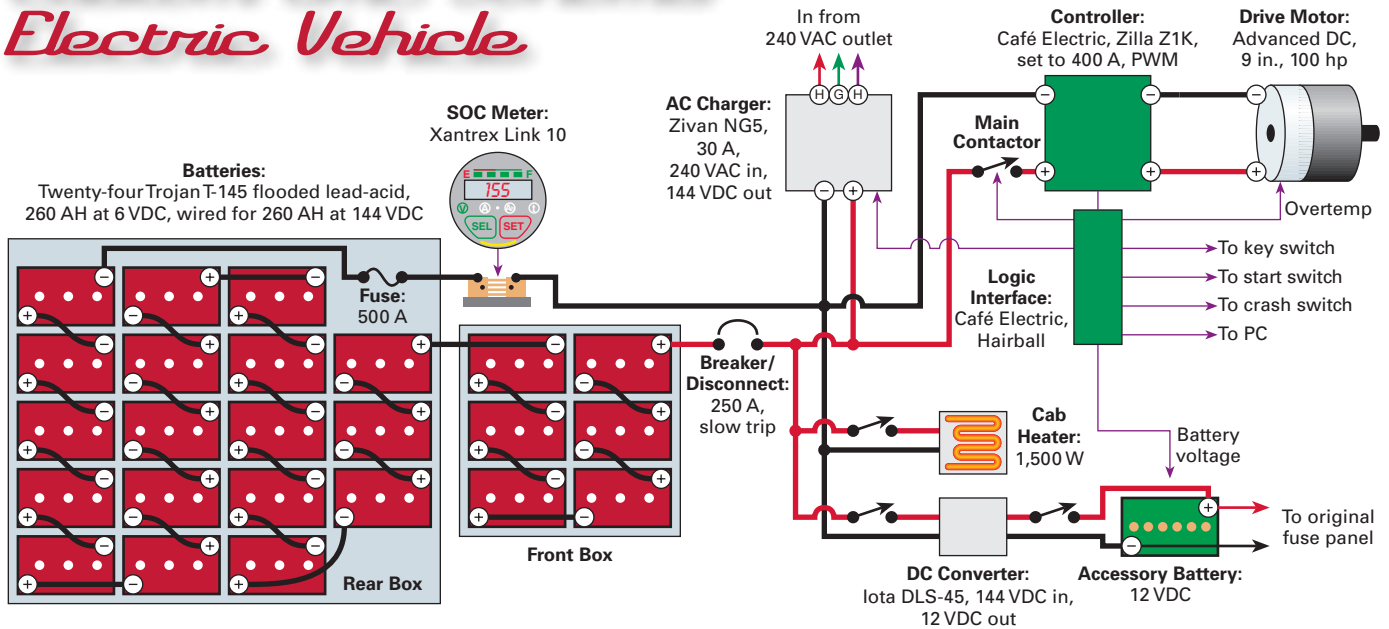

Giving up the Gas

“As always, deconstructing was far easier than constructing,” Richmond says. “This part of the process is straightforward because vehicles are designed to have parts removed and replaced.” Over a month of evenings, he removed the ICE components: the exhaust, fuel, engine cooling, and emission control systems. Removing the engine required extra muscle and an engine hoist, which Richmond bought used for \$100.

He also removed the air conditioning and power steering systems, which can require a lot of extra energy to operate, and pulled out the transmission to make installing the EV motor easier. (He replaced the power steering with a manual steering box from a 1980s-vintage vehicle of the same make.) In total, deconstructing accounted for a quarter of the entire conversion—about 40 hours.

Going Electric

The most time-intensive part of the conversion was installing the EV components. This took Richmond 110-plus hours spread out over a few months. He says that installing the first component—the electric motor—offers the greatest gratification and the greatest challenge. The centerpiece of the kit—an Advanced DC, 9-inch, 100 peak hp motor—provides power comparable to the truck’s original 4-cylinder, 120 hp internal combustion engine (ICE).

It took one long evening for him to install the electric motor on the transmission with the adaptor plate. Though some might have opted to leave the transmission in place and mate the motor under the hood, Richmond had removed the transmission to make connecting the two components easier. The motor mounts on one side of the plate while the transmission mounts on the other side, creating one large, heavy unit.

Placing this cumbersome component where the gas engine used to be was no easy task and warranted an

EV Tech Specs

Overview

- Make & Model:** 2001 GMC Sonoma, extended cab
- Transmission:** 5-speed manual
- Fuel:** 144 VDC, 260 AH, lead-acid batteries (37 KWH)
- Mileage:** 2 miles per KWH
- Fuel Cost:** \$0.04/mi. or \$0.09/KWH
- Top Speed:** 70 mph
- Typical Range:** 40 mi. (leaving 20% battery reserve)

Electric Components

- Motor:** Advanced DC, 9 in., 100 hp peak (30 hp continuous)
- Controller:** Cafe Electric, Zilla Z1K
- AC Charger:** Zivan NG5, 30 A, 240 VAC input, 144 VDC output
- DC Converter:** Iota DLS-45
- System performance metering:** Xantrex Link 10

Energy Storage

- Batteries:** Single string of 24 Trojan T-145, 6 VDC nominal, 260 AH at 20-hour rate, flooded lead-acid
- Battery Bank:** 144 VDC nominal, 260 AH total

Modifications

- Vehicle Curb Weight:** 4,900 lbs. (original: 3,250 lbs.)
- Tires:** Goodyear Regatta II, low rolling resistance, 44 psi



The control box, with the logic interface mounted on its cover.

evening of its own. “It was an exercise in geometry that required two additional people,” Richmond says. “Getting it tilted at just the right angle demands some patience, but we worked it out.” Once positioned, the unit is bolted in place using the kit’s motor mount. Even with the challenge of installing the motor and transmission as a unit, he had no regrets about his decision to remove the transmission. “It was a trade-off,” he says. “Since proper mating is critical, I decided to live with the extra effort to install the combo.”

Positioning the Power

Next came the two prefabricated battery enclosures. Besides keeping the batteries securely fastened, the boxes latch to protect against accidental shock. The insulated aluminum boxes also help keep the batteries warm, since cold temperatures result in a temporary reduction in battery capacity.

The kit’s electrical design required two battery boxes: one in the bed that holds 18 batteries and one under the hood that holds six more. Because he chose batteries that were slightly taller than the boxes were designed for, he had to remove some metal from the edge of the box that could have made contact with the battery terminals and caused an electrical short. At this point, he secured the box in the bed but held off on installing the under-the-hood box because there was still some conversion work to do in the engine compartment.

Under the Hood

In the space once occupied by the air conditioning unit, Richmond installed a 1,500-watt ceramic heater to provide heat for the cab. Securing the piece required Richmond to fabricate a simple mounting plate from sheet metal—an easy-enough task that suited his metal-working skills.

From there, he worked on the power controller and its cooling system—two of the most important components in the electrical system. The pulse-width-modulated (PWM)

The original gasoline filler cap was replaced by a 240 VAC plug.



power controller regulates the power to the vehicle’s drive train by translating the position of the accelerator pedal into power flowing to the electric motor, making the car go.

For every amp that flows to the motor from the controller, 2 watts of waste heat are generated in the controller. At 400 amps, for example, the power controller produces 800 watts of heat. The cooling system circulates water through the controller to cool the electronics, preventing the unit from overheating and causing a thermal shutdown of the Zilla controller.

Outfitting the Cab

With these vital components in place, and after mounting the vacuum pump for the power brakes, the control box, and the remaining battery box above the electric motor, Richmond moved his work from under the hood into the cab. There, he mounted the charger and 45 A DC-DC converter behind the driver’s seat. The extended cab allowed enough room for both components, which should not be exposed to the elements. As an added bonus, the charger produces heat while charging. “When it’s colder outside, I try to charge the truck right before I leave for work. That way I don’t have to run the heater as much, if at all,” Richmond says.

The DC-DC converter charges a 12-volt battery (also in the cab) that powers the vehicle’s accessories—headlights, windshield wipers, radio, etc. This battery is separate from the traction batteries under the hood and in the bed so that the vehicle can operate standard 12 V accessories independently.

Richmond wrapped up the cab components installation by installing a battery SOC meter—what he considers an “absolute must” for EV newbies who tend to overestimate their battery charge. Much like a gas gauge shows the amount of gas in the tank, the SOC meter shows the amount of energy available in the vehicle’s batteries.

Tying up Loose Ends

One of his final tasks—wiring the AC power cabling to the charger—was perhaps the easiest. The AC plug fit perfectly behind the old gasoline filler cap, saving Richmond from enlarging the existing hole.

Last but certainly not least was wiring the three-fold safety system and wiring the batteries to each other. The EV’s safety system includes a 500 A fuse in the rear battery box

that opens the circuit if the system shorts; a breaker in the control box that is connected to a knob on the dash board for emergency disconnect; and an inertia switch in the control box that causes the circuit to open and stop the motor in the event of an accident. Wiring the batteries seems fairly straightforward—connecting the positive terminal of one battery to the negative of the next—but tight connections are vital to performance and preventing the connections from overheating and melting the terminals.

Turning the Key

Then came the moment he had anticipated for more than a year—the test drive. “It’s a nerve-racking moment. You just hope that everything works and no smoke appears,” he recalls.

Rather than running the motor at the full 400 amps, he took gradual steps. Using his laptop connected to the controller’s computer interface, he programmed the power controller for 50 amps—barely enough power to move the vehicle. He adjusted the settings eight times, adding 50 amps each time until reaching the maximum, 400 amps. At each increment, he checked all the components and connections for signs of heat and unusual noises.

Much to his surprise, there was nothing wrong—no melting wires, no smoking connections, no mystery noises. The vehicle was road-ready.

“Every increment of the testing built my confidence,” Richmond says. “When I actually got up speed and drove it a few miles down the road, I was thrilled with the results. The first thing that struck me was the quiet. When I pulled out, the only sound I heard was the gravel beneath my tires. It was such a cool feeling to drive without putting out any exhaust.”

He noticed only one problem during his inaugural ride: a non-responsive speedometer. Turns out, the signal source for the speedometer—the power train computer—had been part of the gas engine system. So he installed an aftermarket speedometer adapter that takes electrical pulses from the transmission and turns them into signals for the speedometer.

Enjoying the Ride

Where once there was a gas cap, there now is a 240 V, 30 A twist-lock AC plug. A vehicle that once drove 400 miles on a 19-gallon tank of gasoline now drives 40 miles when the EV’s batteries are fully charged.

No more gasoline means no more exhaust fumes and none of the maintenance that comes with ICE engines—tune-ups, oil changes, radiator flushes, starter repairs, muffler/exhaust pipe replacements, to name a few. Instead, Richmond performs battery maintenance and system inspections every few months. He looks for signs of heat, bad cables, and poor connections. He also cleans corrosion, tightens connections, and refills the water in the batteries.

Besides eliminating tailpipe emissions, Randy also uses renewable energy sources for recharging the EV’s batteries—an 800-watt grid-tied PV system and grid power purchased from the Green Power program at Puget Sound Energy—eliminating the pollution associated with conventional coal or natural-gas-fired electricity production.

Though he misses A.M. radio reception, which is blocked by interference from the controller’s PWM, Richmond couldn’t be happier with the finished product. “I like driving by the gas station and never stopping,” he says. “I like that I come home and plug in my car, just like plugging in my cell phone.”

One major future expense will be batteries. In four to six years, Richmond will need to replace them or modify the electrical design to run on newer battery technology if it’s available. Either scenario will cost \$3,000 or more. But that’s a small price to pay for a vehicle that could last more than 15 years and cut fuel costs by two-thirds, Richmond says.

Curing the Hiccups

As much as he enjoys his new ride, the vehicle is not without some shortcomings. It struggles to keep up with traffic on steep hills, forcing him to pull onto the shoulder for one hill along his regular commute to let other traffic go by. By opting for larger batteries instead of more batteries and higher voltage, Richmond chose to get more distance rather than have better acceleration. He’d expected to be able to push 1,000 amps to the motor (the full carrying capacity of the power controller), but he learned that flooded lead-acid batteries are limited to about 400 amps because anything higher could overheat and melt the battery terminals. Had he realized this limitation during the design phase, he could have used bigger cabling and added industrial grade terminals, which might have pushed the power limit to 500 or 600 amps.

The weight of the batteries only exacerbates the less-than-optimal acceleration situation. Richmond had wanted to keep the vehicle’s weight under the gross vehicle weight rating (4,600 pounds), but the heavier, 260 AH batteries that he chose pushed the vehicle to 4,900 pounds and only

Out with the ICE

Converting an internal combustion engine vehicle to an EV requires getting into the guts of the machine—and removing many parts and pieces. Here’s a list of those that went by the wayside in preparation for going electric.

- | | |
|--------------------------------|-----------------------|
| Engine | Cooling System |
| Emission System | • Radiator |
| Computer | • Shrouds |
| Air Conditioning System | • Hoses |
| • Compressor | • Fan |
| • Radiator | Power Steering |
| • Chamber | • Pump/Reservoir |
| Air Intake System | • PS box |
| • Ducting | • Hoses |
| • Filter | • Fluid cooler |
| Exhaust System | Fuel System |
| • Muffler | • Gas tank/pump |
| • Catalytic converter | • Hoses/Lines |
| • Pipes | • Filter |
| | • Sensor |

added a few extra miles to the driving range. In retrospect, he says he would have chosen smaller, lighter 225 AH (T-105) batteries. Reducing the amp-hours would have cost him a few miles of driving range but could have saved him about \$1,000 and reduced the vehicle's weight by 300 pounds.

To improve the vehicle's performance, Richmond has made some minor changes. A tonneau cover over the bed not only improves the vehicle's aerodynamics but also prevents unauthorized access to the battery box, which comes with a latch but not a lock. New, low-rolling-resistance tires extend the driving range by a few miles and make manual steering a tad easier on the arms. A data-logging system, which plugs into the battery SOC meter on the dash, helps monitor the vehicle's efficiency. A tow bar, tow lights, and drive line coupling device will make towing easier—just in case he ever runs out of juice.

Despite the few glitches, Richmond enjoys every minute of the EV experience. From start to finish, research to test drive, the conversion took one year. "I've heard stories about people who converted vehicles in a weekend, but I'm a perfectionist. I took my time and learned a lot along the way," he says. "Sure, I made some mistakes, but I'm pleased with the end product and plan to drive it for many years to come."

Access

Kelly Davidson, *Home Power* Associate Editor, is living without wheels (that is, the motorized kind) in New Jersey. She daydreams of the day when bike lanes outnumber freeways and renewable energy powers a national mass transit system.

Randy Richmond, RightHand Engineering, 19310 226th Ave NE, Woodinville, WA 98077 • Phone/Fax: 425-844-1291 • info@righthandeng.com • www.righthandeng.com

EV System:

Café Electric • www.cafeelectric.com • Zilla motor controller

Canadian Electric Vehicles Ltd. • www.canev.com • S-10/Sonoma conversion kit

EV Source • www.evsource.com • Water-cooling system for controller

Manzanita Micro • www.manzanitamicro.com • Battery chargers

Trojan • www.trojan-battery.com • Batteries

Xantrex • www.xantrex.com • Link 10 battery monitor

Zivan • www.zivanusa.com • Battery charger

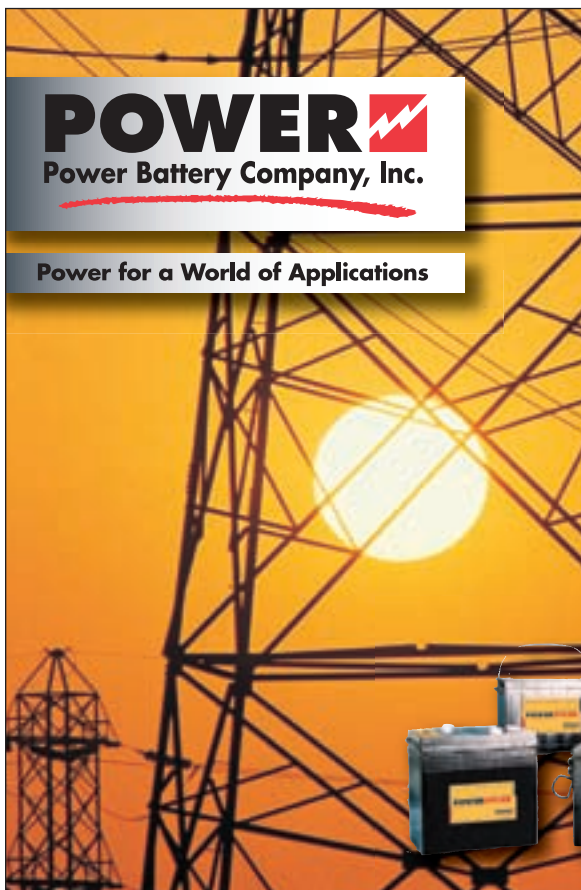

Introducing ADVANCED GEL TECHNOLOGY

Power Battery Company's Advanced Gel Technology (patent pending) is a hybrid technology that combines the best features of Absorbed Glass Mat (AGM) and Gel into one battery. Here's how Advanced Gel Technology can enhance your battery application:

1. The gelled electrolyte in the AGM separator and plates retains the sulfate ion that leaves the plates on recharge. This prevents or drastically reduces acid stratification which extends battery cycle life compared to standard AGM Batteries.
2. This hybrid battery with its manufacturing method, provides better oxygen recombination efficiency and improved water conservation. Standard gel batteries use low porosity, leaf separators which are more resistant to oxygen diffusion and greater water loss.
3. The gelled electrolyte acts as a heat sink which greatly improves the thermal properties of the battery allowing for operation in more severe climates.
4. The gelled electrolyte facilitates greater plate to acid contact to enhance the amp hour capacity of the battery while providing consistency of operation.

**Contact Power Battery
for further information
on the next generation
in sealed battery technology.**

Power Battery Co., Inc. Paterson, NJ
www.powerbattery.com • solar@powbat.com
800-966-4135